

Series **NLCS**

Table Cylinder

Bore size : $\phi 6$, $\phi 10$, $\phi 16$



Guarantee of long life time due to using circulating bearing

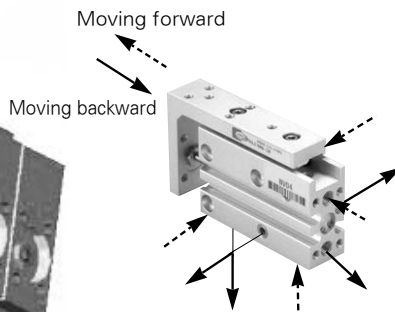
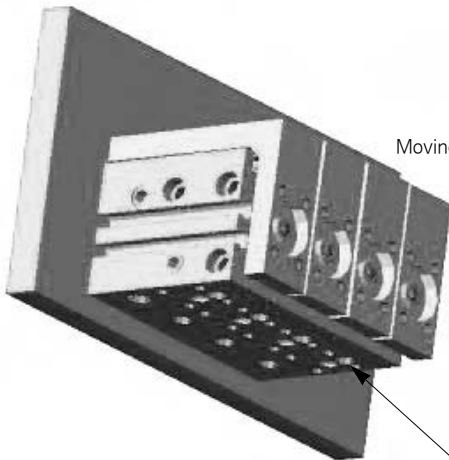
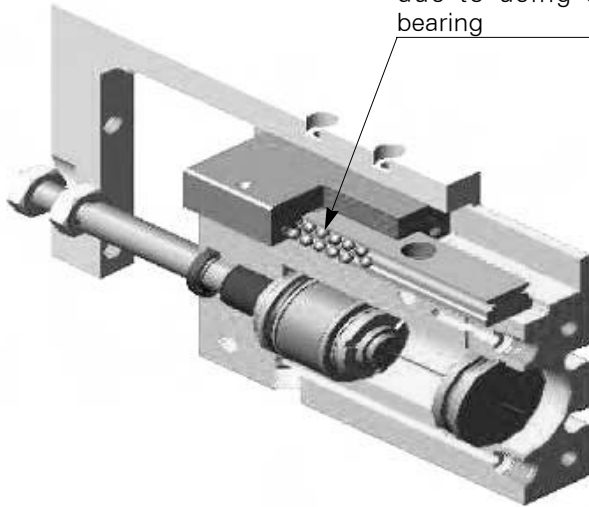

Various application due to adding air supply port on the bottom of table.

1. Side mounting(Body through hole)

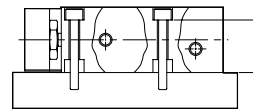

2. Side mounting(Body tapped)



3. Vertical mounting(Body tapped)

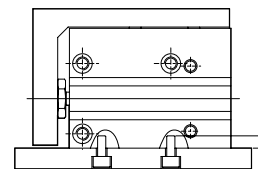

4. Axial mounting(Body tapped)

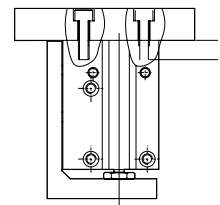

NLCD Variation

Model	Bore size (mm)	Standard Stroke							Auto Switch
		5	10	15	20	25	30	40	
NLCD6	6	■	■	■	■	■	■	-	Reed Switch (W8H) (W8V)
NLCD10	10	■	■	■	■	■	■	■	Solid State Switch (W9H) (W9V) (W9HN) (W9HP)
NLCD16	12	■	■	■	■	■	■	-	

Series **NLCS**

Table Cylinder

Bore size : $\phi 6$, $\phi 10$, $\phi 16$



- Improvement of durability due to using circulating bearing
- Using precise heavy weight bearing block
- Universal mounting

Symbol

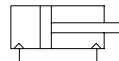

How to Order

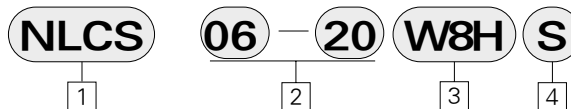

1 Table Cylinder Single Rod

2 Bore size (ϕ mm) - Stroke (mm)

6-5, 10, 15, 20, 25, 30
10-5, 10, 15, 20, 25, 30, 40
16-5, 10, 15, 20, 25, 30

3 Type of Auto Switch

Blank : None
W8V : Reed Switch (Vertical Type)
W8H : Reed Switch (Horizontal Type)
W9H : Solid State Switch (Horizontal Type)
W9V : Solid State Switch (Vertical Type)
W9HN : Solid State Switch (3 Wire, NPN)
W9HP : Solid State Switch (3 Wire, PNP)
※ Standard auto switch lead wire length is 1m.
3m leads available on all models by adding a "L" suffix to the part number. (ex: W8HL, W9VL)

4 Number of Auto Switch

Blank : 2pcs
S : 1pc
n : npc

Series NLCS

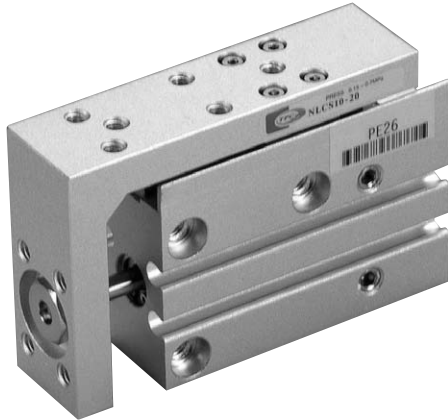

Specifications

Bore size(φ mm)	6, 10, 16
Fluid	Air
Operation	Double Acting
Operating Pressure	0.15~0.7Mpa(21~99psi)
Proof Pressure	1.05Mpa(152psi)
Ambient and Fluid Temp °C(°F)	-10~60°C(14~140°F)
Piston Speed	50~500mm/s
Lubrication	Non Lube
Auto Switch(OPTION)	Exsting plug:DC(24V)/AC(110V) Non plug:DC(24V)
STROKE length tolerance	0~+1mm
Cushion	Rubber Damper(Both side)

Standard Stroke

Model	Standard Stroke						
	5	10	15	20	25	30	40
NLCS6	○	○	○	○	○	○	-
NLCS10	○	○	○	○	○	○	○
NLCS16	○	○	○	○	○	○	-

Weight Table

(Unit:g(l b))

Model	Standard Stroke						
	5	10	15	20	25	30	40
NLCS6	45	50	60	65	75	80	-
NLCS10	95	105	115	120	145	150	★
NLCS16	100	190	230	230	260	280	-

Theoretical Force

(Unit:N)

Model	Operating Direction	Operating Pressure(Mpa(psi))		
		0.3(43.5)	0.5(72.5)	0.7(101.5)
NLCS6	Extention	17	29	40
	Retraction	13	21	29
NLCS10	Extention	30	51	71
	Retraction	23	38	53
NLCS16	Extention	68	113	158
	Retraction	51	85	119

※ Theoretical Force(N) = Pressure(Mpa) × Piston Area(mm²)

1N≒0.102kgf, 1Mpa≒10.2kgf/cm²

Structure

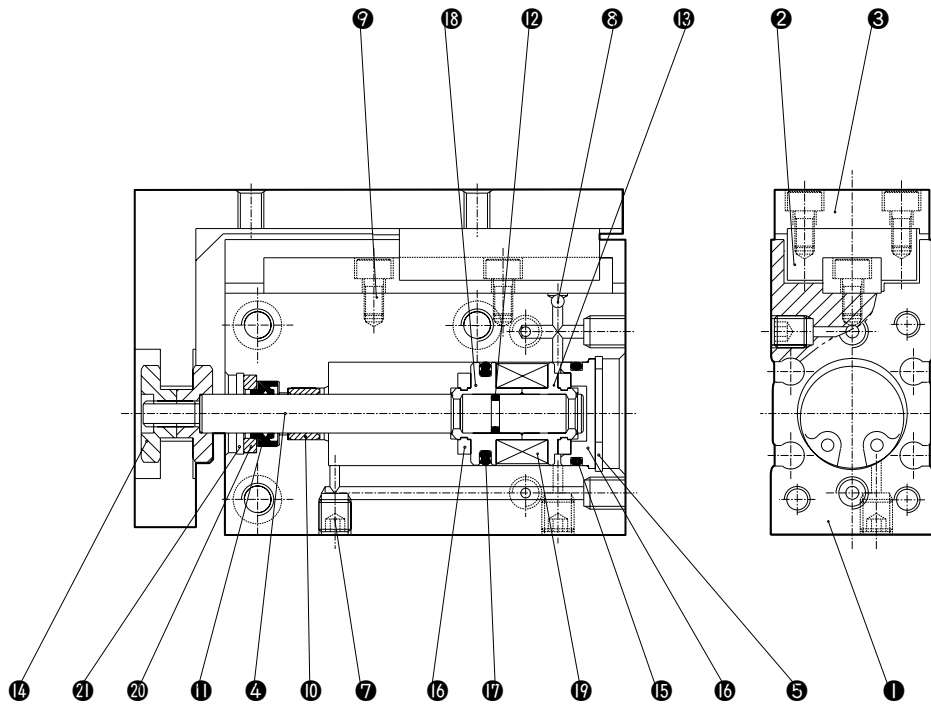

No.	Description	Material	Note			
1	Body	Alluminum Alloy		11	Rod Packing	Rubber
2	Bearing Ass'y	Ally Steel		12	Piston Gasket	Rubber
3	Table	Alluminum Alloy		13	Piston-B	Alluminum Alloy
4	Piston Rod	Stainless Steel		14	Retainer	Brass
5	Snap Ring	Spring Steel		15	Tube Gasket	Rubber
6	Head Cover	Alluminum Alloy		16	Bumper	Polyurethane
7	Headless Wrench Bolt	Stainless Steel		17	Piston Packing	Rubber
8	Ball(φ)	Ally Steel		18	Piston-A	Alluminum Alloy
9	Blanking Plug	Stainless Steel		19	Magnet	Brass
10	Bush	Ally Steel		20	Rod Cover	Brass
				21	Snap Ring	Ally Steel

Spare Parts/Seal Kits

No.	Description	Material	Part. No		
			NLCS6	NLCS10	NLCS16
11	Rod Seal	NBR	KSYR-3	KSYR-4	ORA-6
15	Tube Gasket	NBR	TC1P006-16-1693	TC1P006-16A1694	TC1P006-15A-1695
17	Piston Seal	NBR	OPA-6	OPA-10	OPA-16

Series NLCS

Dimensions NLCS 6

(Unit:mm)

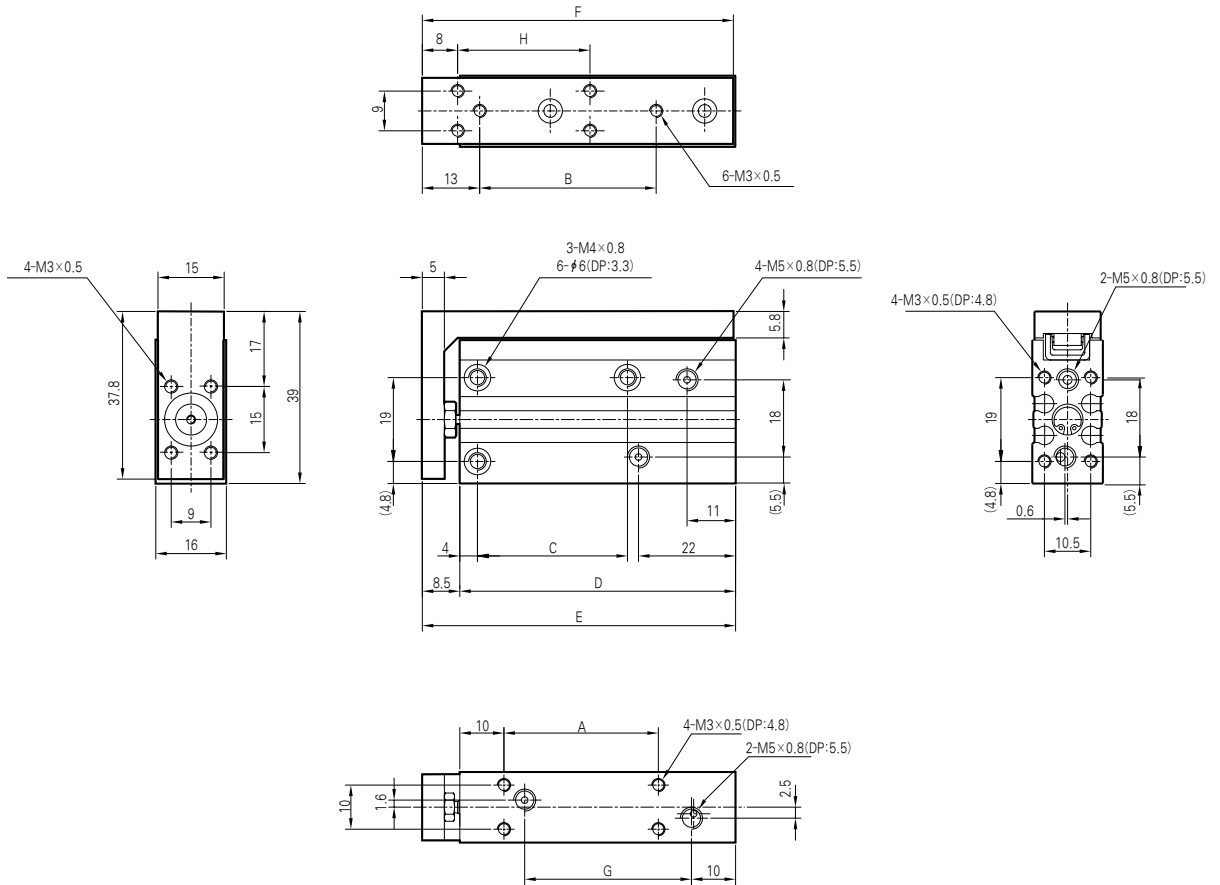

No	Part. No	Stroke	A	B	C	D	E	F	G	H
1	NLCS6-5	5	10	20	14	37.5	46	45.5	17.8	10
2	NLCS6-10	10	15	20	14	42.5	51	50.5	17.8	10
3	NLCS6-15	15	20	25	24	47.5	56	55.5	22.8	20
4	NLCS6-20	20	25	30	24	52.5	61	60.5	27.8	20
5	NLCS6-25	25	30	40	34	57.5	66	65.5	32.8	30
6	NLCS6-30	30	35	40	34	62.5	71	70.5	37.8	30

Dimensions NLCS 10

(Unit: mm)

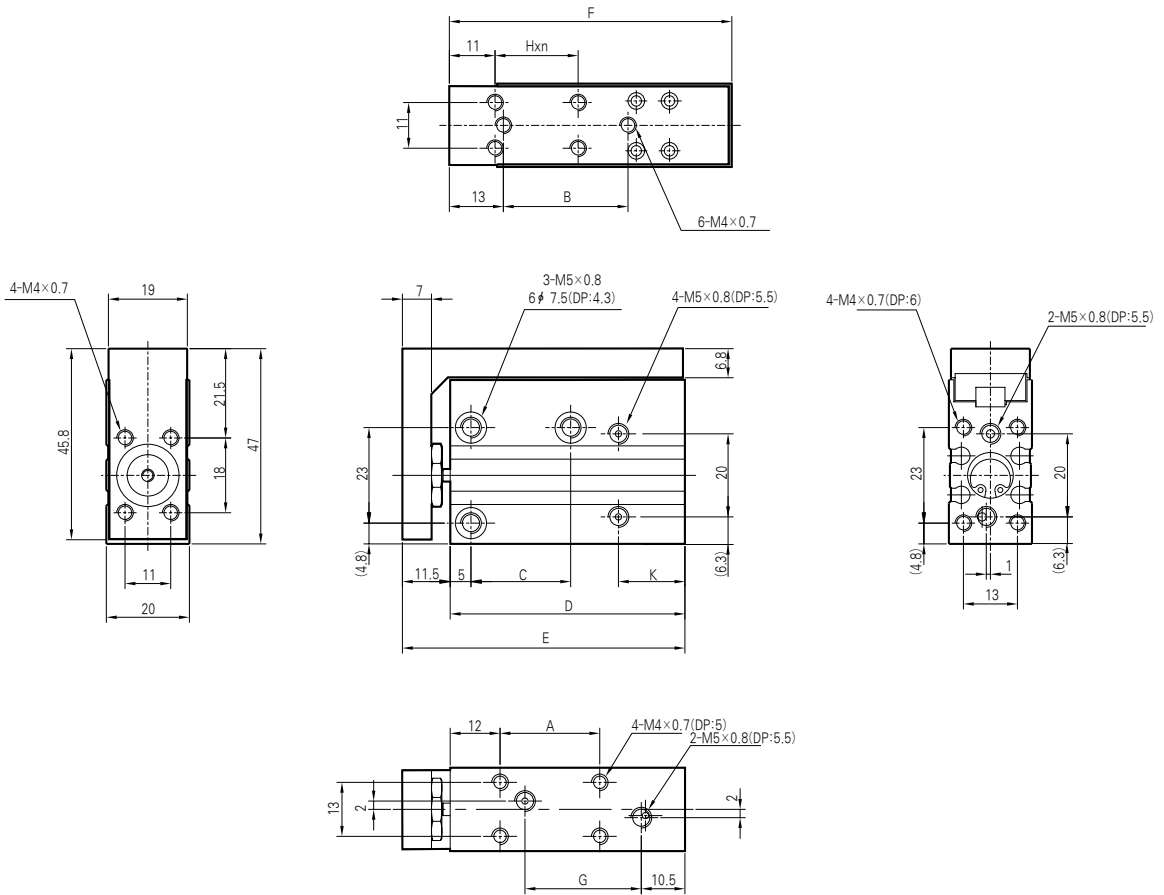

No	Part. No	Stroke	A	B	C	D	E	F	G	Hxn	K
1	NLCS10-5	5	10	14	14	41.5	53	52.5	14.5	10×1	14.5
2	NLCS10-10	10	14	19	14	46.5	58	57.5	19.5	10×1	15
3	NLCS10-15	15	18	25	24	51.5	63	62.5	24.5	20×1	16
4	NLCS10-20	20	24	30	24	56.5	68	67.5	29.5	20×1	16
5	NLCS10-25	25	32	40	34	64.5	76	75.5	34.5	30×1	16
6	NLCS10-30	30	35	45	34	68.5	80	79.5	39.5	30×1	16
7	NLCS10-40	40	45	-	45	76.5	88	79	49.5	20×2	16

Series NLCS

Dimensions NLCS 16

(Unit: mm)

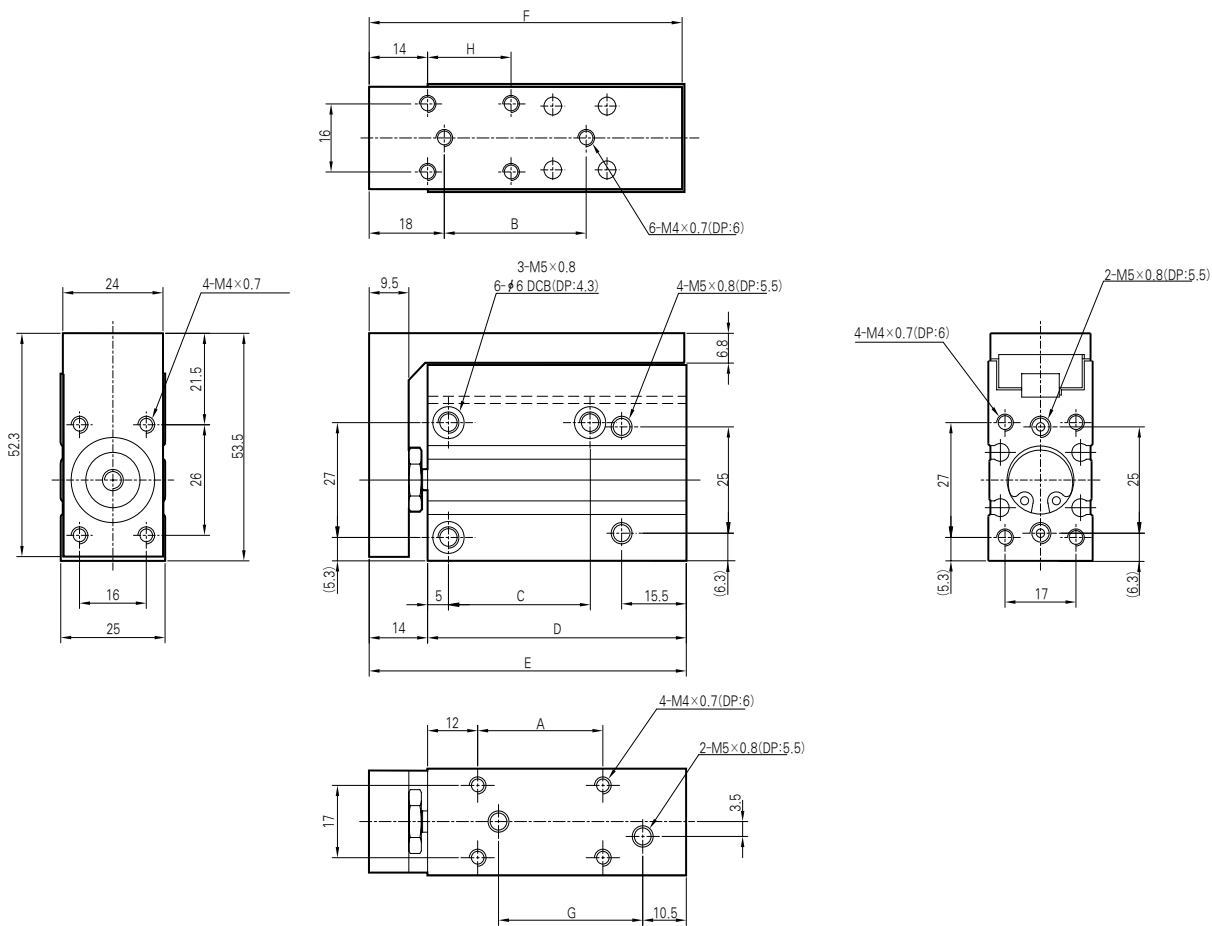

No	Part. No	Stroke	A	B	C	D	E	F	G	H
1	NLCS16-5	5	20	24	24	52	66	65.5	19.5	10
2	NLCS16-10	10	20	24	24	52	66	65.5	24.5	10
3	NLCS16-15	15	30	35	34	62	76	75.5	29.5	20
4	NLCS16-20	20	30	35	34	62	76	75.5	34.5	20
5	NLCS16-25	25	40	45	40	72	86	85.5	39.5	30
6	NLCS16-30	30	45	50	40	77	91	90.5	44.5	30

Cautions for each product in NLCS Series

Be sure to understand these matters before using the products.

Allowable Moment

Type	Stroke	Allowable moment(N.M)			Distance adjustment value for moment position(mm)	
		M1	M2	M3	Cp,Cy	Cr
NLCS6	5	0.046	0.040	0.049	28	7.5
	10	0.046	0.040	0.049	28	
	15	0.061	0.053	0.062	31	
	20	0.061	0.053	0.062	34	
	25	0.076	0.066	0.074	38	
	30	0.076	0.066	0.074	41	
NLCS10	5	1.1	1.1	1.82	30	9.5
	10	0.98	0.98	1.58	38	
	15	0.85	0.85	1.38	45	
	20	0.74	0.74	1.2	45	
	25	0.64	0.64	1.0	55	
	30	0.56	0.56	0.9	55	
	40	0.48	0.48	0.8	55	
NLCS16	5	2.17	2.17	3.21	42	12
	10	1.89	1.89	2.8	42	
	15	1.64	1.64	2.43	56	
	20	1.43	1.43	2.11	61	
	25	1.24	1.24	1.84	61	
	30	1.08	1.08	1.6	71	

Cautions for selection

⚠ Cautions

- Never insert your finger in the gap between table and cylinder tube. When piston rod is moving in, finger can be jammed between table and cylinder tube. So never insert your finger. If finger is jammed, injury may be inevitable, because the power of cylinder is very strong.
- Loading mass and moment must not exceed maximum loading mass and allowable moment.
- In case that the output of table cylinder is directly applied to table, it must be applied on the line of rod axis.(Refer to the following figure)

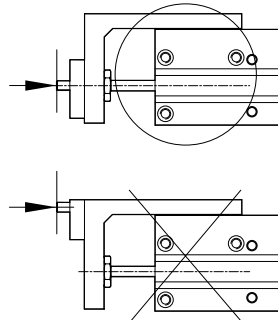

- Be sure to connect speed controller in order to keep the speed below 50mm/s.

Expression to calculate the allowable load $F_p + F_y + F_r$

When PITCH moment is added	When YAW moment is added	When ROLL moment is added
$F_p = \frac{M1 \times 1000}{L_p + C_p + St} \text{ (N)}$ <p>Lp : Distance from table to leading point(mm) Cp : Distance adjusting value for central position of moment(mm) St : Length of stroke (mm).</p>	$F_y = \frac{M2 \times 1000}{L_y + C_y + St} \text{ (N)}$ <p>Ly : Distance from table to leading point(mm) Cy : Distance adjusting value for central position of moment(mm) St : Length of stroke (mm).</p>	$F_r = \frac{M3 \times 1000}{L_r + C_r} \text{ (N)}$ <p>Lr : Distance from table to leading point(mm) Cr : Distance adjusting value for central position of moment(mm)</p>

Cautions

How to install compact slide

- Compact slide can be installed in 4 directions. Select it in accordance with machine or Work.

Horizontal installation type(BODY penetration hole)

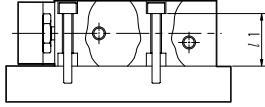

Model	Using Bolt	Maximum Fastening Torque Nm	<i>l</i>
NLCS6	M3×0.5	1.1(11)	12.7
NLCS10	M4×0.7	2.5(25)	15.6
NLCS16	M4×0.7	5.1(25)	20.6

Horizontal installation type(BODY tap)

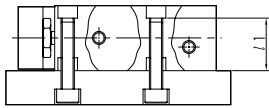

Model	Using Bolt	Maximum Fastening Torque Nm	<i>l</i>
NLCS6	M3×0.5	2.5(25)	9.4
NLCS10	M5×0.8	5.1(52)	11.2
NLCS16	M5×0.8	5.1(52)	16.2

Vertical installation type(BODY tap)

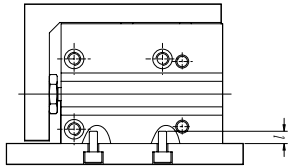

Model	Using Bolt	Maximum Fastening Torque Nm	<i>l</i>
NLCS6	M3×0.5	1.1(11)	4.8
NLCS10	M4×0.7	2.5(25)	6
NLCS16	M4×0.7	2.5(25)	6

Axial direction installation type(BODY tap)

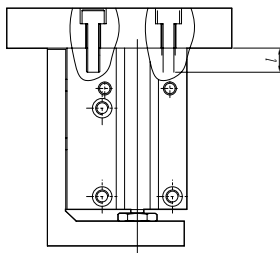

Model	Using Bolt	Maximum Fastening Torque Nm	<i>l</i>
NLCS6	M3×0.5	1.1(11)	4.8
NLCS10	M4×0.7	2.5(25)	6
NLCS16	M4×0.7	2.5(25)	6

How to install Work

- It is possible to install work on the 2 surface of compact slide.
- As table is supported by miniature linear guide, avoid excessive shock or moment when installing work.
- Be sure to support table when fastening work to table by bolt, etc. If body is supported when fastening, guide will undergo excessive moment, thereby deteriorating precision.

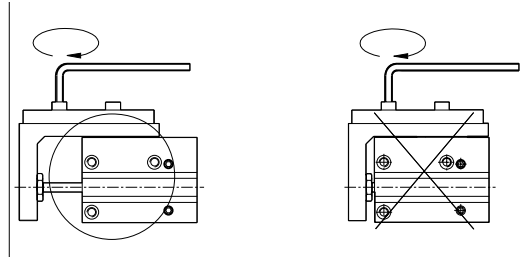

- When connecting to load with external tools of support or guide, be sure to select suitable connecting method and perform position deciding work as much as required.
- If the sliding part of piston rod is damaged or collided, malfunction or air leakage may be caused.

Front surface installation type

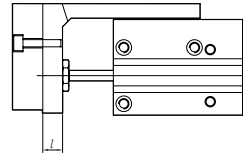

Model	Using Bolt	Maximum Fastening Torque Nm	<i>l</i>
NLCS6	M3×0.5	1.1(11)	5
NLCS10	M4×0.7	2.5(25)	7
NLCS16	M4×0.7	2.5(25)	9.5

Lateral surface installation type

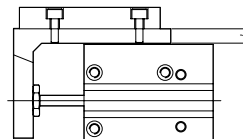

Model	Using Bolt	Maximum Fastening Torque Nm	<i>l</i>
NLCS6	M3×0.5	1.1(11)	5
NLCS10	M4×0.7	2.5(25)	6
NLCS16	M4×0.7	2.5(25)	6

Moving direction of each pressurized port

